

Short Knurled Mold Bushing

A Boneham registered design for Split Molds

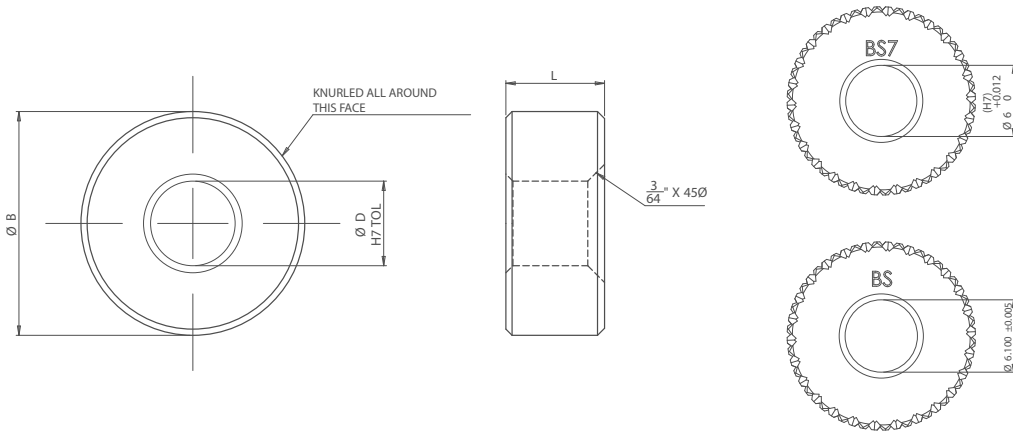

KEY FEATURES

- / Mild Steel
- / Chemically Blacked
- / Deep Knurl
- / Compact Design
- / 7mm Long

APPLICATION

The Short Knurled Mold Bushing is a shortened version of the Knurled Mold Clamp Bushing. The short version does not feature a resin groove, but allows for alignment when depth of locating material is at a minimum and a standard length bushing is not suitable. The short mold clamp is available in two versions. BS: Short version of -B for a fastening bolt BS7: Machined for a locating dowel pin.

ORDERING INSTRUCTIONS

When ordering check the size of bolt and thread required and choose corresponding part number. Example:

- / M8 Bolt: Bushing: GSCL-8MM-BS and Nut: GSCL-8MM-N

If a dowel pin is being used. Example:

- / DP35B 8MM Pin order: Bushing GSCL-8MM-B7 and Nut: GSCL-6MM-N

Bushing Types:

- / BS: Suitable for standard bolts
- / BS7: Suitable for Boneham Dowel Pins

NOTES

- / Can be used as a nut and bushing assembly or with Boneham pins and drill bushings
- / Inch versions available



Knurled Bushing – For use with standard bolt

Part Code	Bore D	Outside Diameter B	Length L	Grooves
GSCL-6MM-BS	8.1mm	5/8"	7mm	0
GSCL-8MM-BS	6.1mm	5/8"	7mm	0

Knurled Bushing – For use with standard Dowels

Part Code	Bore D H7	Outside Diameter B	Length L	Grooves
GSCL-6MM-BS7	6mm	5/8"	7mm	0
GSCL-8MM-BS7	8mm	5/8"	7mm	0